

Field Study of Master Mixing Valve Energy Efficiency Potential

Final Report

ET22SWE0047



Prepared by:
Jose Garcia TRC
Amin Delagah TRC
Matthew Stevens TRC
Daniel Hacking TRC

September 15, 2024

Disclaimer

The CalNEXT program is designed and implemented by Cohen Ventures, Inc., DBA Energy Solutions (“Energy Solutions”). Southern California Edison Company, on behalf of itself, Pacific Gas and Electric Company, and San Diego Gas & Electric® Company (collectively, the “CA Electric IOUs”), has contracted with Energy Solutions for CalNEXT. CalNEXT is available in each of the CA Electric IOU’s service territories. Customers who participate in CalNEXT are under individual agreements between the customer and Energy Solutions or Energy Solutions’ subcontractors (Terms of Use). The CA Electric IOUs are not parties to, nor guarantors of, any Terms of Use with Energy Solutions. The CA Electric IOUs have no contractual obligation, directly or indirectly, to the customer. The CA Electric IOUs are not liable for any actions or inactions of Energy Solutions, or any distributor, vendor, installer, or manufacturer of product(s) offered through CalNEXT. The CA Electric IOUs do not recommend, endorse, qualify, guarantee, or make any representations or warranties (express or implied) regarding the findings, services, work, quality, financial stability, or performance of Energy Solutions or any of Energy Solutions’ distributors, contractors, subcontractors, installers of products, or any product brand listed on Energy Solutions’ website or provided, directly or indirectly, by Energy Solutions. If applicable, prior to entering into any Terms of Use, customers should thoroughly review the terms and conditions of such Terms of Use so they are fully informed of their rights and obligations under the Terms of Use, and should perform their own research and due diligence, and obtain multiple bids or quotes when seeking a contractor to perform work of any type.

Executive Summary

The California Plumbing and Energy Codes do not mandate master mixing valves (“MMV”) for temperature control of domestic hot water (“DHW”) recirculation systems. While some applications, such as large multifamily buildings, elder care facilities, and other segments may require the use of mixing valves for health and safety reasons, there are many applications where DHW recirculation systems have been installed without the use of MMV. Prior research, for multifamily buildings, funded for the Codes and Standards Enhancement Initiative (CASE) by PG&E’s Codes and Standards program shows water heating energy savings for various split heat pump-based heating plant configurations ranging from 6.5% to 18% when adding a DMMV versus no MMV setup and tempering at the dwelling unit level. Additionally, non-condensing and condensing gas-fired systems were previously estimated to yield 3% water heater energy savings (California Energy Codes & Standards, 2023)

This study is focused on high performance MMV, known as electronic or digital master mixing valves (DMMV) that are designed for use with operation of recirculation loops and handle the dynamic nature of variable flow water draws downstream at the point-of-use. The objectives for this project are to determine the energy consumption impacts of installing master mixing valves in commercial and multifamily facilities, and to compare the data to prior lab studies of electric heat pump water heater (HPWH) performance. Other objectives include demonstrating performance of the DHW system with and without MMV, such as operating efficiency, optimizing the DMMV setpoint, and documenting non-energy benefits associated with each site.

The research team achieved the objectives by installing DMMV and field monitoring at five sites including a full-service restaurant, a multifamily building, a senior living facility, an eye clinic, and a hotel. The research team monitored cold water temperature, hot water temperature, hot water draws, and energy input to the hot water system. The system types included a HPWH, integrated tank type gas water heaters, and a gas split system. The team calculated energy savings and operating efficiency and reported on several operating parameters such as cycle time, cycle frequency, and operating set points to provide additional context to the reader.

The findings show that DMMV are estimated to reduce water heating energy use by 4.5% on average, based on observations from five field sites. The savings observed varied, ranging from 11.4% to 4.9%. Savings were achieved for condensing and non-condensing integrated tank type gas systems and for non-condensing split tank type gas systems, however the HPWH site did not achieve savings which contradicts prior lab testing. The research team believes that savings are possible with the HPWH, but that HPWH are more sensitive to water heater set point; In this study, the team increased the HPWH set point by 2 °F based on observations at prior sites and did not have the opportunity to test different set points due to challenges at the site. More work is needed to determine savings potential for HPWH. The results show that DMMV have energy savings potential, but integration into energy programs should account for the likely level of skill of the contractor for light commercial applications. Key recommendations include providing training to the installing contractor and performing quality control when the DMMV is installed as part of a retrofit. The research team observed non-energy benefits that should be marketed including reduced runouts and increase of tank temperatures to kill waterborne pathogens while managing scald risks.

Abbreviations and Acronyms

Acronym	Meaning
BTU	British Thermal Unit
CASE	Codes and Standards Enhancement Initiative
DHW	Domestic Hot Water Recirculation Systems
DMMV	Digital Master Mixing Valve
EE	Energy Efficiency
ET	Emerging Technology
GHG	Greenhouse Gas
HP	Heat Pump
HPWH	Heat Pump Water Heater
IOU	Investor-Owned Utility
kWh	Kilowatt-hour
M&V	Measurement and Verification
MBH	Thousands of BTU per hour
MMV	Master Mixing Valve
MMMV	Mechanical Master Mixing Valve
PA	Program Administrator
PG&E	Pacific Gas & Electric
SCE	Southern California Edison
SDG&E	San Diego Gas & Electric

Acronym	Meaning
SSL	Secure Sockets Layer
TPM	Technology Priority Map
WH	Water Heating

Table of Contents

Abbreviations and Acronyms	iv
Introduction.....	7
Background	8
Objectives and Methodology	10
Retrofit Measure	10
Site Selection	11
Field Metering	12
Analysis.....	14
Site Descriptions	17
Site 1 (Full-Service Restaurant).....	17
Site 2 (Multifamily Building).....	18
Site 3 (Senior Living Facility).....	20
Site 4 (Eye Clinic).....	21
Site 5 (51-unit Hotel)	21
Findings	23
Site 1 (Full-Service Restaurant).....	23
Site 2 (Multifamily Building).....	30
Site 3 (Senior Living Facility).....	36
Site 4 (Eye Clinic).....	41
Site 5 (51-unit Hotel)	47
Key Findings.....	53
Results and Recommendations.....	57
References	59

Introduction

Master Mixing Valves (MMV) are meant to mix hot, cold, and recirculation system return water in a safe manner in domestic hot water distribution systems. They are found throughout both the residential and non-residential segments, and their use decouples the hot water system storage temperature from the hot water supply temperature enabling water-borne pathogen mitigation and reducing scalding risks, among other benefits.

Although they are common in certain segments, the value of electronic or digital master mixing valves (DMMV) as an energy saving measure is only just beginning to be studied. These devices have been shown to have significant energy savings potential in lab settings due to increased tank stratification and lower average hot water distribution system temperatures, but there is limited research of their energy savings potential in real-world applications. This study is specifically focused on studying the energy savings associated with installation of DMMV in recirculation systems in commercial and other non-residential segments.

The purpose of this study is to demonstrate the energy impact of DMMV in real-world applications and report on impacts to overall system performance. Furthermore, this study includes limited characterization of the five demonstration sites and discusses how real-world factors, such as crossover and backflow, impact the successful implementation of DMMV. This study targeted a variety of sites in the light commercial sector including:

- Full-service restaurant
- Multifamily building (21-units)
- Senior living facility (20-units)
- Eye clinic
- Hotel (51-rooms)

Key findings from this study can be used in future utility program development, such as in retrofit or retro-commissioning programs, new construction programs, and codes and standards enhancement (CASE).

Background

The California Plumbing and Energy Codes do not currently mandate MMV for temperature control of domestic hot water (DHW) recirculation systems. A code change proposal to the California Energy Code recently added a prescriptive requirement for mechanical or thermostatic master mixing valves for multifamily buildings to the 2025 adoption of Title 24 Part 6. While some applications such as large multifamily buildings, hospitals, elder care facilities and other segments often include the use of MMV for health (pathogen mitigation) and safety reasons (scalding prevention), there are many applications where DHW recirculation systems have been installed without the use of MMV.

This study is focused on high performance DMMV, which are designed for use with operation of recirculation loops and handle the dynamic nature of variable flow water draws downstream at the point-of-use. DMMV may have additional monitoring, remote adjustment, and other components and controls built in depending on the manufacturer and model as compared to other MMV. They are much more advanced than the conventional wax type thermostatic mechanical master mixing valve (MMMV) and various other thermostatic/mechanical types available on the market, many of which were not designed for operation with variable water draw distribution systems with recirculation return loops. Currently, American Society of Sanitation Engineers 1017-2009 standard addresses MMV performance but is not representative of real-world operation since the standard doesn't verify if the device performs thermostatic mixing or if it can accommodate high recirculation return temperatures. Prior field studies have not investigated the energy savings potential of DMMV in recirculation systems.

Figure 1 illustrates piping of systems with and without the DMMV and the effect of DMMV on tank stratification. The illustration applies specifically to integrated heat pump water heater (HPWH) and integrated gas water heaters. The Domestic Hot Water CASE report describes other possible configurations in greater detail (California Energy Codes & Standards, 2023).

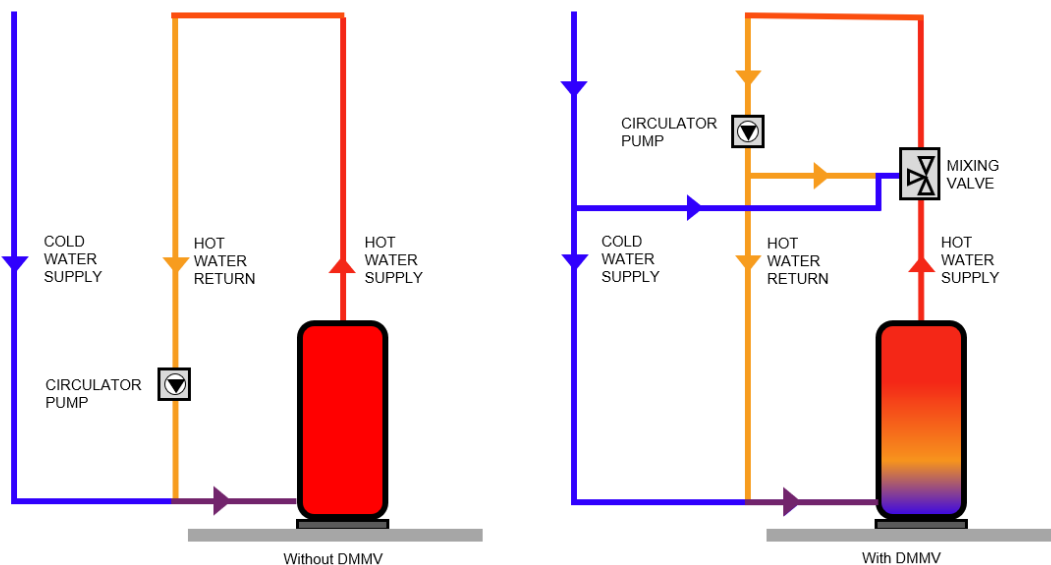

Figure 1: Integrated tank type water heater with and without DMMV.

DMMV reduce the impacts of short cycling and tank destratification by diverting a large fraction of the recirculation water to flow back to the distribution system via the cold water supply inlet to the mixing valve as opposed to 100% flow through the water heater and or storage tank. DMMV can also increase the effective capacity of water heating systems if the operator chooses to set the tank temperature setpoint higher while maintaining a lower temperature setpoint at the DMMV. This functionality can be especially important for heat pump water heating systems to enable load shifting and to manage slower tank temperature recovery by increasing effective storage to avoid hot water runouts. Increasing storage capacity can also reduce the input rate requirements reducing space needs, electrical capacity requirements, and first costs in some cases. This does come with a slight energy penalty because the heat pump water heater will operate at slightly lower COP at elevated setpoint temperature and there will be slightly greater standby losses with a higher tank temperature setpoint, but this method has the potential to supply hot water through peak electrical costs without activating the HPWH by implementing advanced controls.

DMMV can also reduce the temperature fluctuations throughout the recirculation system because they maintain the recirculation loop temperature, independent of whether the water heater is cycling. Typically, the thermostat has a 7-10 degree deadband thus at a 125F setpoint temperature, the heater may deliver water at 130F when tank is fully heated and only delivery 120F hot water prior to activating the HP. DMMV increases comfort for the end-user and can also reduce energy consumption by removing temperature spikes in the recirculation loop that may deliver higher temperature than desired to the user which may be wasteful depending on the application and if the water is tempered at the tap. The temperature spikes increase pipe heat losses which translates to increased energy use at the heater especially when continuous recirculation systems are utilized.

Objectives and Methodology

The primary objective for this project is to determine the energy consumption impacts of installing master mixing valves in commercial and multifamily facilities, and to use the data collected to verify previous lab testing energy savings results from CASE. Other objectives include demonstrating performance of the DHW system with and without MMV, such as the water supply temperature deadband and operating efficiency, optimizing the DMMV setpoint, and documenting potential non-energy benefits such as more precise control of the hot water supply temperature and changes to the water heater setpoint, which can increase storage capacity.

The research team completed the objectives of this project by conducting five field DMMV retrofit projects and documenting energy savings and other findings. The project team installed four DMMV in gas water heating systems and one in a heat pump system. Heat pump water heating systems are not yet common in commercial buildings in California, and there is a lack of data for the energy savings potential of DMMV in the field that can support code readiness and programs.

Retrofit Measure

The retrofit measure consists of installation of a new Armstrong DMMV from the DRV product line. The valve is intended for use in continuously recirculated hot water systems, although in some cases the research team installed the DMMV in systems without continuously recirculated hot water in consultation with the manufacturer. The valve has programmable set points and requires specific software and a cable connection to update the set points which gives the research team more strict control over who can alter the valve set point.

The research team selected the appropriate DMMV set point to reduce average hot water supply temperature without compromising the utility of hot water delivered to the critical fixture. In this case, the utility of hot water delivered is determined by the temperature requirement at the critical fixture which in turn dictates the minimum temperature required at the outlet of the water heating plant. Because the temperature deadband associated with the DMMV is much smaller than the temperature deadband of a typical water heater, it's possible to reduce the average hot water supply temperature without reducing utility as illustrated in Figure 2.

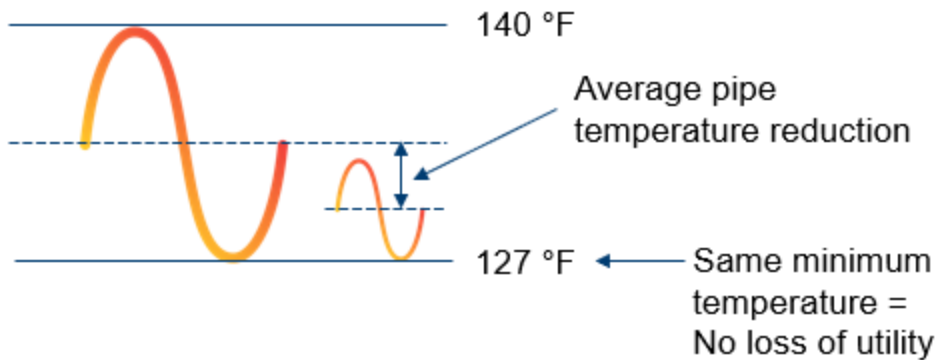

Figure 2: Conceptual illustration describing the research teams' approach to selecting DMMV set point

The manufacturer supported the project by furnishing the valves and providing sizing based on prescriptive methods, and other technical support. The sizes and key specifications for valves installed in this study are listed in Table 1.

Table 1: Retrofit Package Product Options and Key Specifications

Product	Inlet and Outlet Connection Sizes	Rated flow at 10 PSIG Pressure Drop	Minimum Rated Recirculation Flow Rate
DRV25	1" NPT	31 GPM	2 GPM
DRV40	1-1/2" NPT	70 GPM	5 GPM
DRV80	3" NPT	133 GPM	10 GPM

Site Selection

To achieve the objectives of demonstrating savings in the target market of commercial and multifamily buildings, the research team ruled out sites with characteristics that are not representative of the general commercial market including:

- Use of district water heating
- Limited or excessive use patterns

The research team also ruled out sites with characteristics that are easy to identify and significantly reduce the energy savings potential associated with DMMV. These sites are a lower priority target for future energy programs. This included sites with:

- Tankless water heaters
- Electric resistance storage tanks
- Recirculation demand control based on temperature
- Existing MMV

Additional criteria for site selection included whether the existing system was operating safely and whether the recirculation system had timer controls. Examples of unsafe operation include operations that could increase the risk of waterborne pathogens or scalding, such as a water heater setpoint below 120°F or if the water heater setpoint is above 120°F but hot water returns below 120°F. When the existing system was not operating safely, the research team educated the owner and would consider the site if they increased the tank setpoint to achieve safe temperatures throughout the recirculation system. When considering systems with timer controls, the team's primary concern was that the timer would reduce energy savings. The project team considered hot water systems with timer controls on a case-by-case basis.

Field Metering

The research team designed the field metering approach to quantify the average energy savings from DMMV for each site and assess the impacts of DMMV installation on the hot water system performance. The research team monitored each site for a month pre- and post- retrofit. The research team installed the field metering and DMMV at the same time and implemented a bypass to switch between the pre-retrofit system and the post-retrofit system. Figure 3 is a schematic illustration of the bypass and field metering installation.

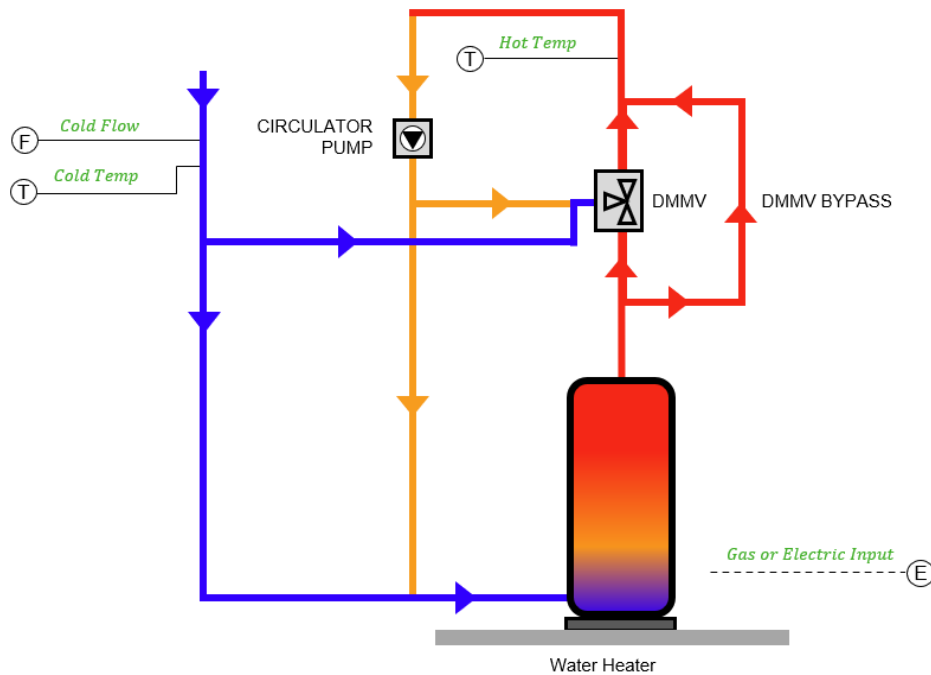

Figure 3: Field-metering Schematic

The project team monitored energy input and the independent variables that impact energy output, including hot water draw, hot water supply temperature, cold water inlet temperature, and inlet air temperature for the heat pump system. The field metering approach also allowed the team to characterize the system operating efficiency; for DHW systems with recirculation accounts for real world heater efficiency or COP along with heat losses of the storage tanks and piping of the heating plant and recirculation loop pipe heat losses. The operating efficiency is reflective of the energy the water heater uses, water heating that is delivered to the branches and end uses and ultimately the cost to the operator to run the system. The data acquisition (DAQ) system was configured to sample hot water demand and hot water supply temperature at a high frequency, which enables more accurate characterization of the efficiency and basic data validation checks. Table 2 shows the data collection points, instrumentation, and monitoring frequency.

Table 2: Data Collection Points and Instrumentation

Parameter	Type	Manufacturer/Model	Unit	Sampling Interval
Hot Water Supply	Temperature	Dwyer 10k Ohm Thermistor	°F	5-second
Cold Water	Temperature	Dwyer 10k Ohm Thermistor	°F	1-minute
Cold Water (Option 1)	Flow Rate	Badger Nutating Meter	GPM	5-second
Cold Water (Option 2)	Flow Rate	Fuji FSV-1 with FSSD3 transducers (0.5" – 4" pipe Diameter),	GPM	5-second
Gas (Option 1)	Flow Rate	American meter AC250-NX-TC	CFH	1-minute
Gas (Option 2)	Flow Rate	American Meter AL425	CFH	1-minute
Electrical	Power	eGauge EG4015 true power meter	kW	1-minute

Analysis

The research team analyzed the data to characterize energy use, system operating efficiency, and key performance metrics that affect the efficiency, such as number of water heater on/off cycles. As system performance is a function of mass flow rate and temperature rise of water through the water heater, the team implemented a mass weighting function that weights the measurement of the cold water and hot water temperatures by the mass flow rate of hot water use. All average cold water and hot water temperature data in this report is reported as the mass weighted average unless noted otherwise. The team averaged cold water and hot water temperatures by day and totalized flow rate, energy input, and delivered hot water energy by day. Variable nomenclature can be found in Table 3.

Table 3: Variable Nomenclature

Variable Symbol	Variable Type	Variable Units
q	Thermal energy	$kBTU$
ρ	Density	lbm/ft^3
V	Volume (water or fuel)	gal or ft^3
c_p	Specific heat for constant pressure	$BTU/lbm * ^\circ F$
T_{hot}	Temperature	$^\circ F$
T_{cold}	Temperature	$^\circ F$
E_{in}	Input energy (fuel or electrical)	$kBTU$
$Volts$	Voltage	$Volts$
I	Current	$Amps$
PF	Power Factor	kW/kVA
n_{phases}	Number of electrical phases	$[-]$
Y	Calculated normalized energy use	$kBTU/day$
m	Regression Slope	$kBTU/Gallon$
X	Baseline period daily water use	$Gallons/Day$
b	Regression intercept (non-zero)	$kBTU/day$
$AMCWT$	Arithmetic mean of daily average cold water temperatures	$^\circ F$
η	Efficiency	$kBTU/kBTU$

The project team calculated the heating energy delivered to the hot water distribution system (Delivered Hot Water Energy) at each time step according to Equation 1, assuming a constant density of water at 8.33 pounds per gallon. Although cold water temperature data is sampled at a lower frequency than flow rate or hot water supply temperature, variations in cold water temperature are small and slow, so the team performed the calculation at the same frequency as the high-frequency data and referenced the last sampled cold water temperature. The team totalized Delivered Hot Water Energy daily for further analysis of the daily data.

Equation 1: Delivered Hot Water Energy per interval

$$q [kBTU] = \frac{(\rho * V) * c_p * (T_{hot} - T_{cold})}{1000}$$

For the site with a HPWH the team calculated energy input according to Equation 2. For sites with natural gas water heaters the team converted from cubic feet of natural gas to energy input using an assumed heating value of 1.039 kBTU/ft³ per cubic foot as described in Equation 3. The research team totalized Energy Input daily for further analysis of the daily data. System efficiency is calculated for each day based on the daily totalized delivered hot water energy divided by the daily total energy input.

Equation 2: Electrical Energy Input per interval

$$E_{in} [kBTU] = \frac{Volts * I * PF * (\sqrt{n_{phases}}) * 3.412 * \frac{timestep}{3600}}{1000}$$

Equation 3: Gas Energy Input per interval

$$E_{in}[kBTU] = V * 1.039$$

To calculate energy savings associated with the DMMV the team modeled the energy use for the pre- and post- monitoring period based on the following process:

1. Develop a single-variable linear regression of the daily energy input with daily water use as the independent variable for each distinct baseline and post-retrofit period. In cases where daily cold water temperature varies by more than 10 °F during the monitoring period, bin the data further into periods of high and low cold water temperature to enable a meaningful regression.
2. Calculate the energy results for each distinct baseline and monitoring period using the regression according to Equation 4. Normalize the results to the average baseline daily water use by plugging in the baseline daily water use value as X for both each baseline and associated post-retrofit periods.
3. Normalize the calculated results to the baseline CWT according to Equation 5.

Equation 4: Linear Regression Equation

$$Y_{Uncorrected} = m * X + b$$

Equation 5: Cold Water Temperature Normalizing Equation

$$Y = Y_{uncorrected} + \frac{(\rho * V_{daily}) * c_p * (AMCWT_{Retrofit} - AMCWT_{Baseline})}{1000 * \eta_{retrofit}}$$

Site Descriptions

Site 1 (Full-Service Restaurant)

Site 1 is a full-service restaurant located in Santa Rosa, California with an integrated 250 MBH 100-gallon Bradford White condensing type natural gas-fired water heater. The restaurant operates seven days a week from 11 a.m. to 9 p.m. or 10 p.m. Prep work starts at 8 a.m. Figure 4 provides context regarding the size of site. Table 4 shows the hot water fixtures at the site.



Figure 4: Street view of Site 1.

The water heater is located in a mechanical room on the second floor of the restaurant. The water heater setpoint is set to 140°F. An analog timer control serving the circulator pump is set to turn the circulator pump off at 12:30 a.m. and on again at 5 a.m. Although the controls reduce the savings attributable to the DMMV, the project team decided to work with the existing controls due to their

limited operation. The circulator pump was broken and not operating at the initial site visit, but the owner was willing to allow the project team to replace the pump. After replacing the circulator pump, the team observed that the controls actually turn the circulator pump off from approximately 1 a.m. to 5:30 a.m. Other relevant observations included the lack of an existing check valve and expansion tank at the cold water inlet to the water heater, two existing tempering valves serving lavatories in the bathrooms to prevent scalding, and slightly more complex piping layout in the mechanical room than expected based on experience at other similar sites, and fiberglass insulation of typical installation quality in good condition with some deterioration and lack of insulation at appurtenances. The research team also found evidence of plumbing crossover, which is when hot water inadvertently enters the cold water system (or vice versa), in the system during the monitoring period.

Table 4: Hot Water Fixtures Observed at Site 1

Hot water fixture	Quantity
Double Rack Door-Type Dish Machine	1
Glass Washer Dish Machine	1
Compartment Sinks	2
Pre-Rinse Sprayer	1
Bar Sinks	1
Pot Fill Station	1
Mop Sink	2
Hand Sinks	2
Lavatories	8

Site 2 (Multifamily Building)

Site 2 is a 21-unit multifamily building located in Downey, California with an integrated 270 MBH 100-gallon Bradford White atmospheric combustion natural gas fired water heater. Figure 5 4 illustrates the size of site.



Figure 5 4: Street view of Site 2.

Source: Google Maps

The water heater is located in a mechanical room on the first floor of the building. Most of the piping is concealed but the visible piping indicates that the recirculation system is a single loop system. The project team noticed and resolved several problems with the original water heating system, including that the water heater was originally piped incorrectly with the hot water return pipe feeding directly into the hot water supply pipe and that the water heater setpoint was originally 153 °F. The two problems may have been related since the piping would tend to temper the delivered hot water temperature and since 153 °F water would typically result in complaints, but the owner was unaware of any problems. The research team worked with the owner and the contractor to resolve both issues at the same time and to choose an appropriate setpoint for the baseline system based on the procedures the contractor would typically use for such a site. The contractor chose a setpoint of 130 °F with feedback from the research team to make sure hot water supply temperatures did not exceed 140 °F.

There is no timer or Aquastat (temperature) control and the circulator pump runs 24/7, which is common. Other relevant observations include a lack of an existing check valve and expansion tank at the cold water inlet to the water heater and signs of significant crossover in the data.

Table 5: Hot Water Fixtures Observed at Site 2

Hot water fixture	Quantity
Kitchen Sink	21
Bathroom Sink	21
Shower/Bath Combo	21
Top Loading Washer	2
Basin Sink	1

Site 3 (Senior Living Facility)

Site 3 is a senior living facility with multiple DHW systems. The project team monitored the DHW system serving a wing of 20 dwelling units, each with one bathroom. The DHW system is a Raypak split system heater with a 399 MBH input roof mounted atmospheric combustion natural gas fired heater and a fully insulated 100-gallon tank located in a mechanical room. Figure 656 is provided for reference.



Figure 65: Street View of Site 3

While commissioning the field metering equipment the team noted that the observed natural gas input rate is approximately 2/3 of the rated input rate. The project team consulted the heater manufacturer to try to understand the construction of the heater and whether there are multiple burners (thinking that one is not firing). The manufacturer confirmed that there are multiple burners but could not determine how many. Further troubleshooting did not identify an issue with the metering equipment, indicating the issue is with the equipment, which is estimated by the owner to be 25 years old.

Most of the piping is concealed, but the existing distribution system appears to be insulated with average quality considering the age of the system and includes visible gaps in the insulation. The team also confirmed the presence of an existing check valve on the cold-water inlet. The site previously had a thermostatic master mixing valve, but the operator removed the pre-existing mixing valve prior to this study due to poor performance. The water heating system was previously set to 120 °F, and the team raised concerns about the temperature being too low for the application when considering Modern ASHRAE Guidelines and Standards for pathogen mitigation including ASHRAE Guideline 12 and ASHRAE Standard 118. The operator agreed to increase the water heating setpoint to 125 °F for the baseline period to address these concerns, and in the post-retrofit period the team raised the tank temperature further to 145 °F to meet DMMV manufacturer guidance to improve DMMV response time and reduce temperature excursions.

There is no timer or Aquastat control and the circulator pump runs 24/7. Showers are operated on a schedule. Hot water fixtures are listed in Table 6.

Table 6: Hot Water Fixtures Observed at Site 3

Hot water fixture	Quantity
Shower	20
Bathroom Sink	20

Site 4 (Eye Clinic)

Site 4 is an eye clinic within a larger healthcare facility. The DHW system is an integrated modulating 399.9 MBH 119-gallon A.O. Smith condensing natural gas fired water heater. The water heater is located in a mechanical room on the first floor of the building. Most of the piping is concealed, but the piping that is visible appears to be well insulated with fiberglass insulation and clearly marked labels and jacketed elbows.

The system has an existing check valve and expansion tank, an existing constant speed circulator pump that operates 24/7, and a balancing valve at the return pipe. The tank temperature is set to 140°F. We did not receive permission to add a photo of the site for reference.

The site was originally installed with a high-low mixing valve system with two mixing valves feeding the hot water supply pipe, but the existing mixing valves were disabled and bypassed prior to initial outreach to the site, and the system operates as if the valves are not installed. Table 7 lists the hot water fixtures. According to the plumbing contractor, the hand sinks have automatic sensors and are programmed to purge water at specific intervals to reduce the risk of waterborne pathogens. This results in water use on weekends and at night when the building is not occupied.

Table 7: Hot Water Fixtures Observed at Site 4

Hot water fixture	Quantity
Hand Sinks	33
Mop Sink	1

Site 5 (51-unit Hotel)

Site 5 is a hotel with 51 dwelling units and a suite. The DHW system consists of two integrated AO Smith CHP-120 HPWH. The water heaters are located in a mechanical room on the first floor of the building. Most of the piping is concealed, but the visible piping is un-insulated. The system has an existing check valve and expansion tank and an existing circulator pump with a demand control system that was not programmed. The project team did not get a fixture count from the site. Figure 7 illustrates the site for reference.



Figure 7: Street View of Site 5

Before beginning data collection, the site had issues with inadequate ventilation and had to relocate the HPWH from their original location. Additionally, at site screening, the team observed several factors that negatively impacted performance, including tank temperatures originally set to 140 °F (HPWH 1) and 120 °F (HPWH 2), despite the fact that the HPWH are piped in parallel. Additionally, the team observed a lack of balancing between the HPWH, including piping that is not piped in a reverse-return configuration. In discussion with the contractor, this setpoint setup was intentional in trying to offset the water flow imbalance in the parallel tank setup and ensure parity with duty cycles of both units. The contractor attempted to recommission the demand controller after the HPWH were re-located. Our monitoring data did not show pump deactivation during the monitoring period, thus demand controller was not operational. As part of the research team's work with the site, the team helped the site address these issues while minimizing impact to the study. Some of the changes were made during the duration of this project and others continued after report publication.

Findings

Site 1 (Full-Service Restaurant)

The research team installed the Armstrong DRV40 DMMV at Site 1 in early March 2024. The team performed monitoring at Site 1 from March 7th through May 16th, 2024. There are three distinct monitoring periods. Table 8 lists key dates associated with Site 1. During the field demonstration, the team observed that cold water temperature varied by as much as 14°F. Although the research team was not able to find a root cause for this behavior, the variation is significant enough to affect the results. To overcome this challenge, the team also binned the data according to cold water temperature with a bin for low and high cold-water temperature resulting in five distinct monitoring periods. The analysis excluded the days that the team commissioned the DMMV or increased the DMMV setpoint from the analysis.

Table 8: Site 1 Key Dates

Description	Dates (2024)
Baseline monitoring period	3/7 – 4/11
Commission DMMV	4/12
Post-retrofit monitoring period 1 (135°F)	4/13 – 4/23
Increase DMMV setpoint	4/24
Post-retrofit monitoring period 2 (137°F)	4/25 – 5/16

Table 9 demonstrates the energy savings results based on regression of the daily average results and corrected for different cold water temperatures. During both post-retrofit periods there were significant temperature excursions below the set point as demonstrated in Figure 8. Based on the experience of the research team which includes lab testing of DMMV, the temperature excursions appear to be normal and are due to the DMMV response time to cold water draws. Although the site didn't notice a reduction in functionality, both post-retrofit periods have distribution temperature excursions below the baseline, making the savings values more consistent with an optimized savings value. On the other hand, because Site 1 includes timer control of the pump, savings associated with the DMMV is reduced compared to what it would be without timer control.

Table 9: Energy Savings Associated with Installing the DMMV

Description	Natural Gas Use (kBtu/day)	Natural Gas Savings (kBtu/day)	Natural Gas Savings (%)
Baseline High CWT	735	N/A	N/A
Post-retrofit High CWT (DMMV 135 °F)	661	74	10.0%
Post-retrofit High CWT (DMMV 137 °F)	651	84	11.4%

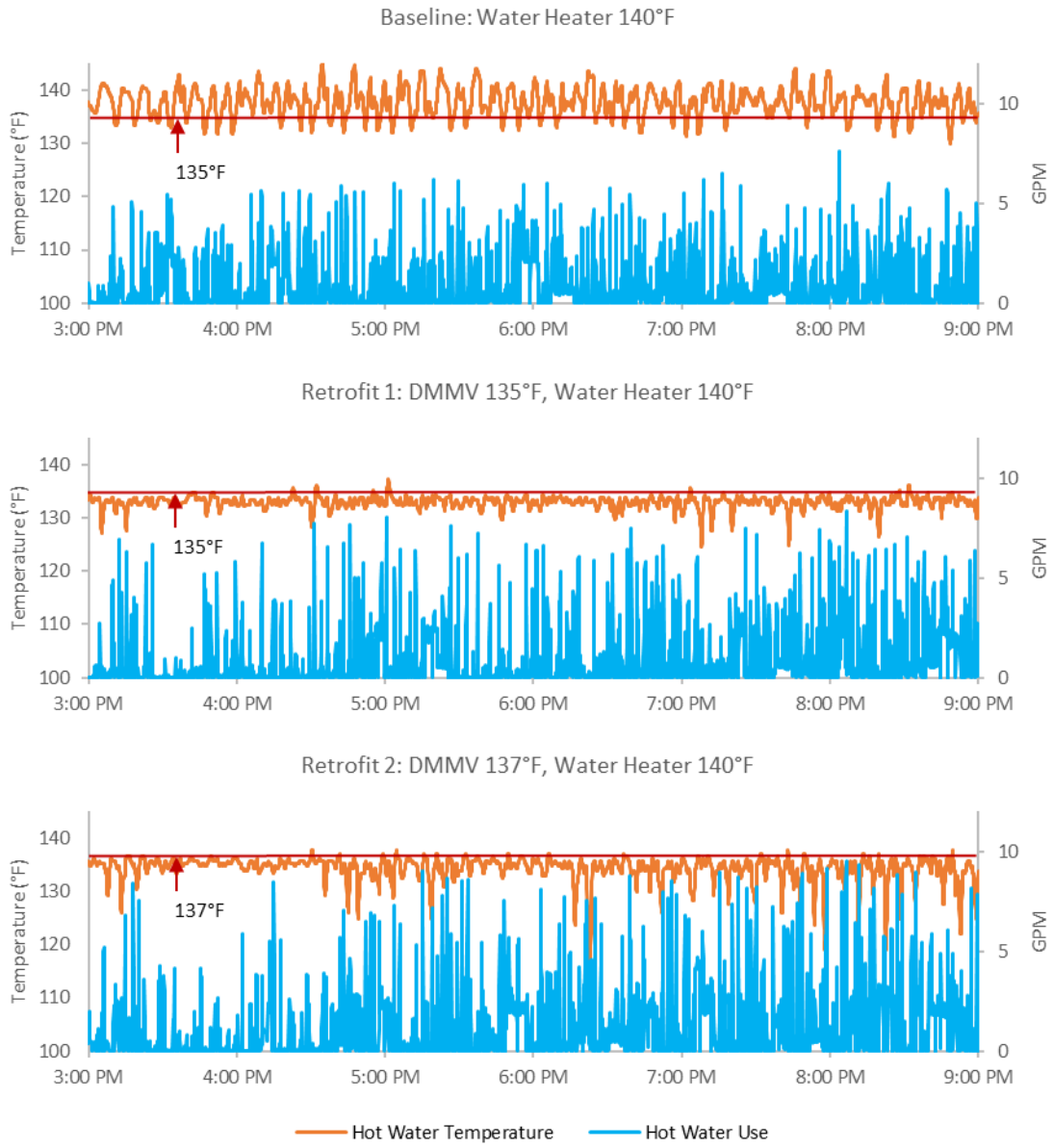

Figure 8: Site 1 DMMV Hot Water Delivery Performance Comparison

Although the results show a higher savings when the DMMV setpoint is higher, Figure 96 which illustrates the daily energy performance of the hot water system over the study period, highlights the variability in the two post-retrofit monitoring periods. The research team interprets the result to mean that the savings associated with the change in setpoint from 137 °F to 135 °F is low compared to natural variability from day to day in the water heating system. Because there are only three days of post-retrofit data with low CWT and because the R² value of the linear fit to this data is less than 0.1, periods of low CWT are excluded from the results. The results demonstrate a significant reduction in energy use despite known issues with the existing water heating system including significant crossover and back flow.

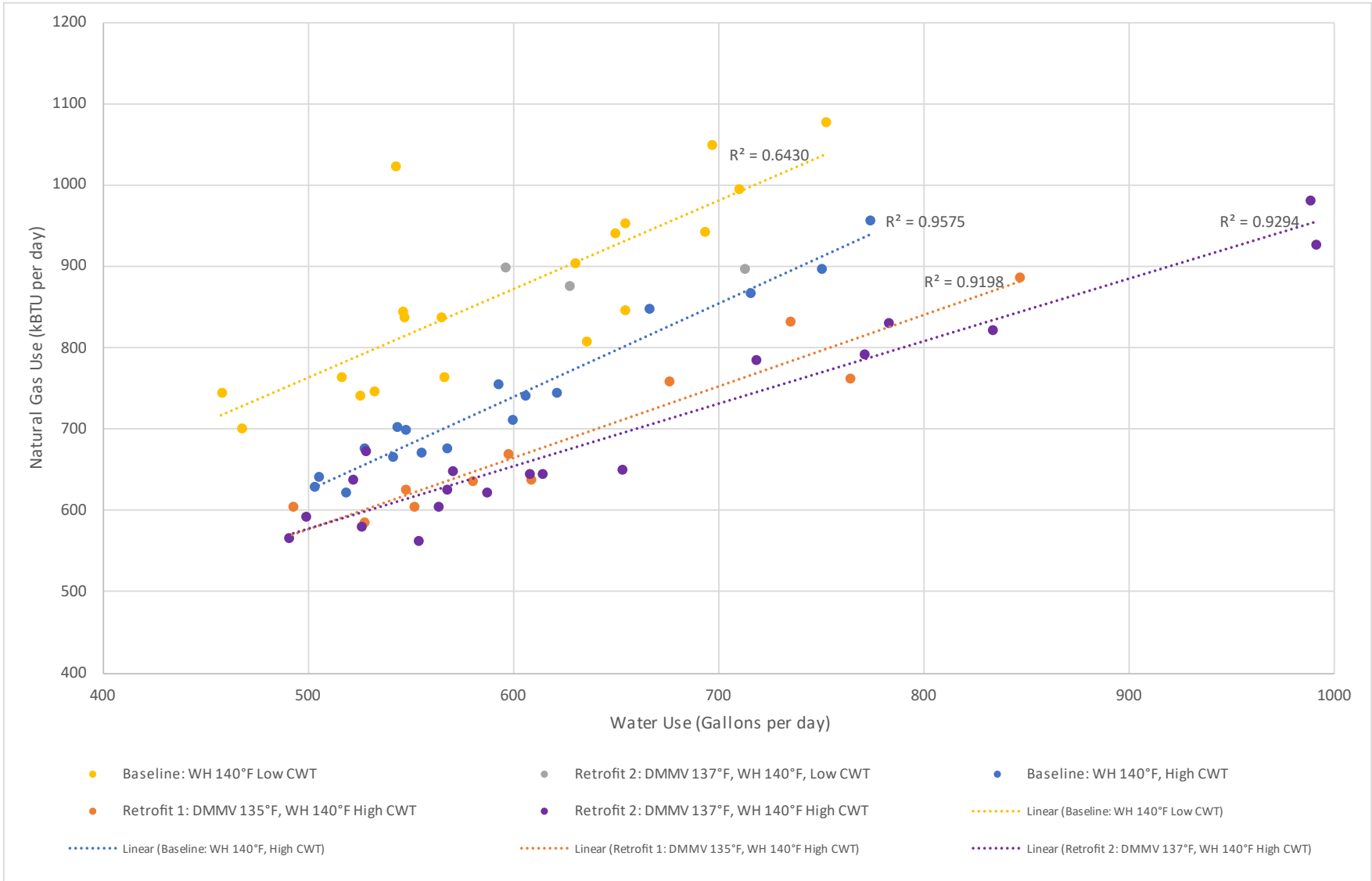

Figure 9: Site 1 Energy Performance

Table 10 documents the typical daily system performance during the field demonstration including water use, temperatures, efficiency, and water heater cycling. Notable observations include that the system short cycles with average cycle times of less than three minutes, and the number of cycles per day is higher than expected. The short cycling can be explained by high heat losses in the recirculation system which the research team attributes to crossover and high heat losses from the piping, combined with a small tank temperature deadband. For the high CWT temperature monitoring periods, water use is higher after installation of the DMMV, yet the number of cycles and total run time is slightly lower which indicates that the DMMV reduces the observed short cycling. Although the low CWT data doesn't show a similar trend, this could be explained by natural variability in the system combined with a sparsity of low CWT post-retrofit data. For the post-retrofit periods, the data shows that the average hot water temperature is significantly lower than the DMMV set point. The research team had to surface mount the temperature sensors due to poor installation of the thermowells by the installing plumbing contractor, and this can explain approximately 2 degree F reduction in measured temperature versus actual hot water temperature in the pipe. Additionally, temperature excursions were observed due to DMMV response time which also reduces the average CWT, and the research team worked with the manufacturer to limit temperature excursions at future sites.

Table 10: Site 1 Daily System Performance

Description	Length (Days)	Water Use (Gal)	Avg. CWT ¹	Avg. HWT ¹	Avg. ΔT ¹	Natural Gas Use (kBTU)	Delivered Hot Water Energy (kBTU)	Operating Efficiency	Total Heater Run Time (minutes)	Avg. Daily Heating Cycles
Baseline Low CWT	19	597	60.9	137.6	75.4	869	382	43.9%	345	141
Post-retrofit Low CWT (DMMV 137 °F)	3	645	63.9	133.8	68.1	890	376	42.2%	352	144
Baseline High CWT	17	596	69.8	137.6	66.4	735	337	45.8%	301	133
Post-retrofit High CWT (DMMV 135 °F)	11	630	70.5	132.9	60.9	691	327	47.4%	288	127
Post-retrofit High CWT (DMMV 137 °F)	19	651	71.1	134.3	61.4	693	342	49.4%	290	129

¹ Reported average temperatures are arithmetic means of the daily average values

Site 2 (Multifamily Building)

The research team installed the Armstrong DRV40 at Site 2 in early April 2024. The research team performed monitoring at Site 2 from April 20 – July 8. Baseline monitoring lasted from April 20 through May 23rd, at which point the contractor activated the DMMV. Due to an installation error when activating the DMMV, the DMMV was improperly commissioned for about a week, so post-retrofit monitoring didn't commence until June 1. During the post-retrofit period the team implemented the DMMV with two tank setpoints. Originally the tank setpoint was maintained at 130°F consistent with the baseline. Based on the observed DMMV behavior at this setpoint, the team consulted with the DMMV manufacturer and increased the tank setpoint to 153°F based on their recommendations.

Table 11: Site 2 Key Dates

Description	Dates (2024)
Baseline monitoring period	4/20 – 5/23
Commission DMMV	5/31
Post-retrofit monitoring period 1 (DMMV 133°F, Water Heater 130°F)	6/1 – 6/20
Increase Water Heater Setpoint	6/21
Post-retrofit monitoring period 2 (DMMV 133°F, Water Heater 153°F)	6/22 – 7/8

Table 12 demonstrates the savings results based on regression of the daily average results and corrected for different cold water temperatures. Both post-retrofit periods show savings, however during post-retrofit period 1 the DMMV exhibits significant and prolonged excursions below set point as demonstrated in Figure 107. These temperature excursions are prolonged compared to what was seen at Site 1, and this is due in part to the deadband of the water heater at Site 2 which has a larger deadband range than Site 1. The large deadband range means there are extended periods where the DMMV is unable to meet its set point due to insufficient temperature from the water heater.

The research team spoke to the manufacturer of the DMMV based on the results and was advised to increase the water heater set point to 20°F above the DMMV set point which is generic guidance intended to ensure intended valve operation. The research team followed the manufacturer's advice eliminating hot water supply temperature excursions and achieving equivalent or better hot water delivery performance than baseline, however the energy savings were significantly reduced but still

positive. This result highlights potential for energy and non-energy benefits which may include increased legionella kill, increased hot water capacity, and demand flexibility potential for only a marginal reduction in savings for integrated tank type water heaters. The research team’s hypothesis is that the additional heat loss from the storage tank at elevated setpoint is offset by the stratification benefits from using the DMMV. The research team decided to test different water heater set points at subsequent sites to understand if the manufacturer guidance for water heater set point can be reduced to improve savings. The results also demonstrate the DMMV saves energy despite significant observed system deficiencies including backflow and crossover.

Table 12: Site 2 Normalized Energy Savings Associated with Installing the DMMV

Description	Natural Gas Use (kBtu/day)	Natural Gas Savings (kBtu/day)	Natural Gas Savings (%)
Baseline (Water Heater 130 °F)	989	N/A	N/A
Post-retrofit 1 (DMMV 133 °F, Water Heater 130 °F)	923	67	6.8%
Post-retrofit 2 (DMMV 133 °F, Water Heater 153 °F)	980	10	1.0%

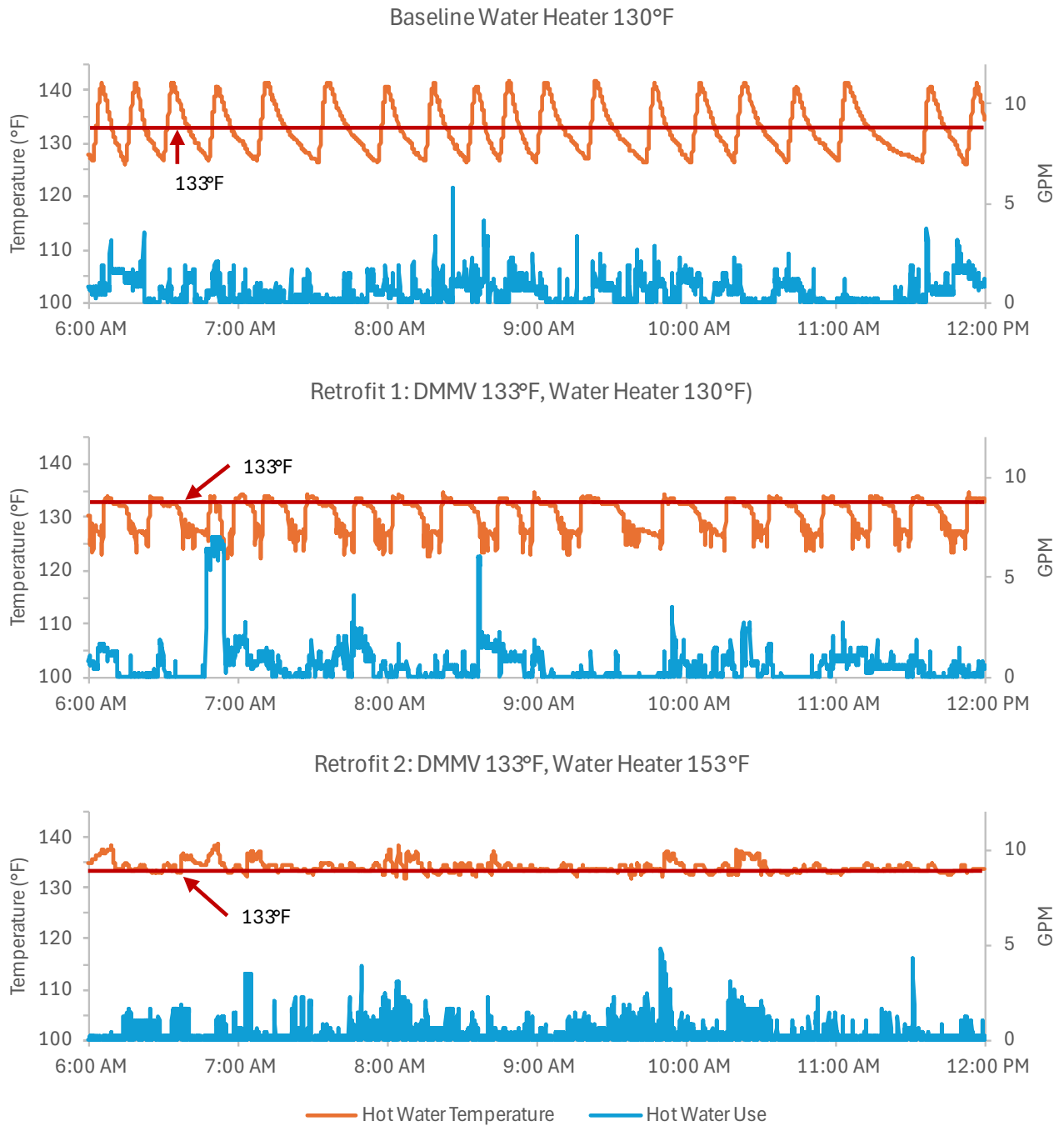

Figure 10: Site 2 DMMV Hot Water Delivery Performance

Figure 11 illustrates the daily energy performance of the hot water system over the study period and is provided for additional context when interpreting the results. Table 13 summarizes the daily system performance during the monitoring period. The data indicates minor differences in efficiency,

run time, and number of cycles. The data is provided for context, however, it is challenging to draw meaningful conclusions due to variation in cold water temperature and daily water usage.

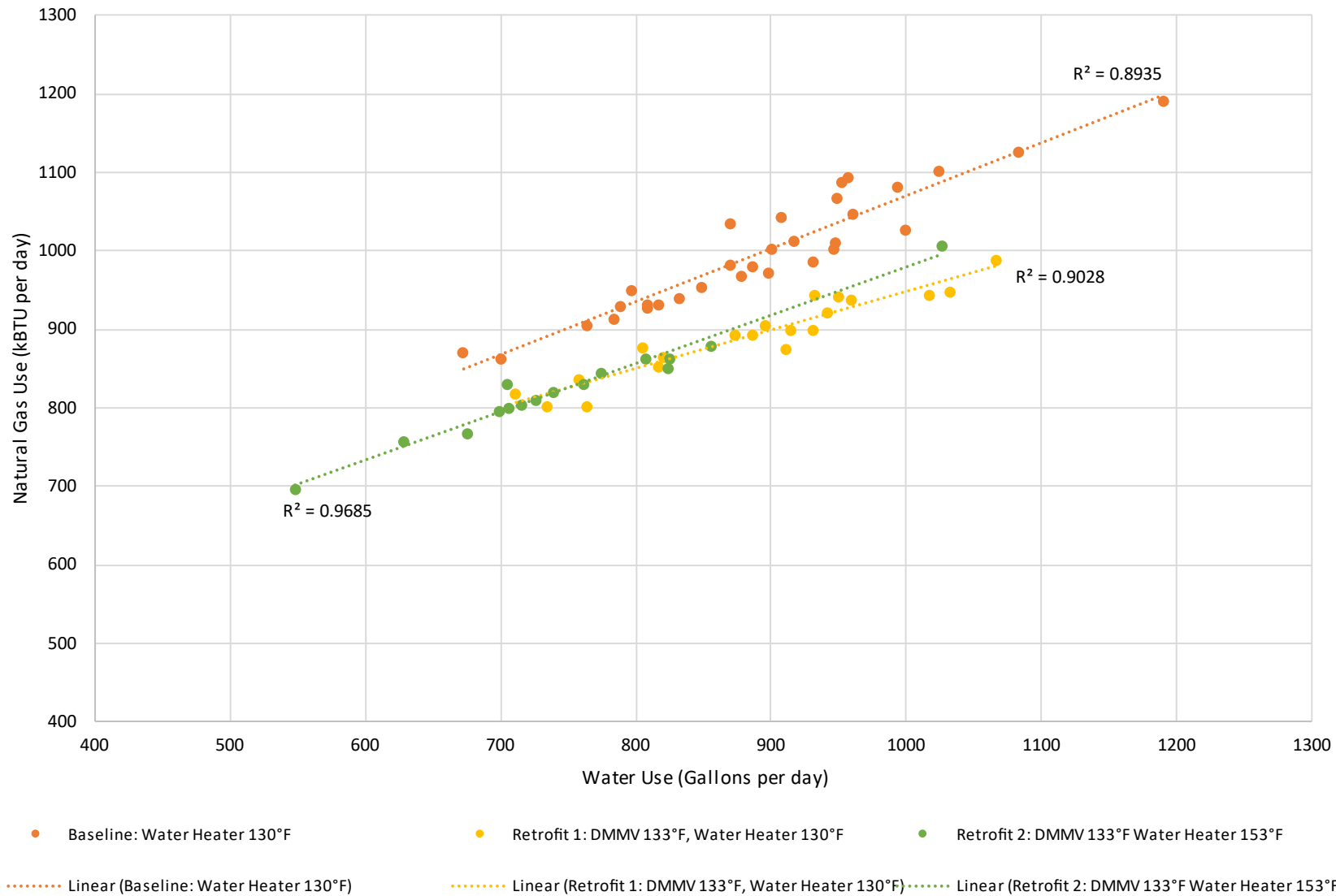

Figure 11: Site 2 Daily Water Use vs. Natural Gas Use

Table 13: Site 2 Daily System Performance Summary Statistics

Description	Length (Days)	Water Use (Gal)	Avg. CWT ²	Avg. HWT ²	Avg. ΔT ²	Natural Gas Use (kBTU)	Delivered Hot Water Energy (kBTU)	Operating Efficiency	Total Heater Run Time (minutes)	Avg. Daily Heating Cycles
Baseline	33	881	72.0	132.5	60.5	989	445	44.8%	328	76
Post-retrofit 1	20	886	74.1	130.4	56.3	893	416	46.5%	309	73
Post-retrofit 2	16	751	77.1	134	56.9	827	357	43.0%	284	67

² Reported average temperatures are arithmetic means of the daily average values

Site 3 (Senior Living Facility)

The research team installed the Armstrong DRV-40 DMMV at Site 3 in late May 2024. Baseline monitoring ran from May 24 through July 1, 2024. There are three monitoring periods: baseline, and two post-retrofit periods where the team tested the effects of varying water heater set points on the delivery performance and energy results. Table 14 lists the key dates associated with Site 3. The split gas water heater and storage tank at Site 3 intermittently stopped operation and hot water delivery temperatures dropped below 120°F. The days where this occurred were not included in the data set for analysis. Additionally, days where setpoints changed or equipment was commissioned are also excluded.

Table 14: Site 3 Key Dates

Description	Dates (2024)
Baseline monitoring period (Heater 125°F)	5/24 – 7/1
Commission DMMV	7/2
Post-retrofit monitoring period 1 (DMMV 125°F, Heater 140°F)	7/3 – 7/30
Post-retrofit monitoring period 2 (DMMV 125°F, Heater 130°F)	8/1 – 8/19

Table 15 demonstrates the energy savings results for site 3 based on regression of the daily average results and corrected for different cold water temperatures. Both periods had better distribution system performance than the baseline period as demonstrated by Figure 128. Figure 128 demonstrates that the baseline system had challenges with hot water run out events, and that installation of the DMMV reduced the occurrence of these run out events because of the additional storage heating capacity. Additionally, the results show that the manufacturer’s recommendation for water heater set point can be reduced for split gas water heating systems to 5°F higher than the DMMV set point with no significant hot water supply temperature excursions and no negative effect on hot water delivery performance. When the water heater set point was 140°F energy use increased, but at a water heater set point of 130°F the savings is significant at 7.3% while improving delivery performance. These results are important in that they highlight significant savings even for split gas water heating systems. Due to the site characteristics, the research team couldn’t optimize performance by further lowering the DMMV set point.

Table 15: Site 3 Normalized Energy Savings Associated with Installing the DMMV

Description	Natural Gas Use (kBTU/day)	Natural Gas Savings (kBTU/day)	Natural Gas Savings (%)
Baseline	1057	N/A	N/A
Post-retrofit 1 (DMMV 125 °F, Heater 140 °F)	1095	-46	-4.4%
Post-retrofit 2 (DMMV 125 °F, Heater 130 °F)	973	76	7.3%

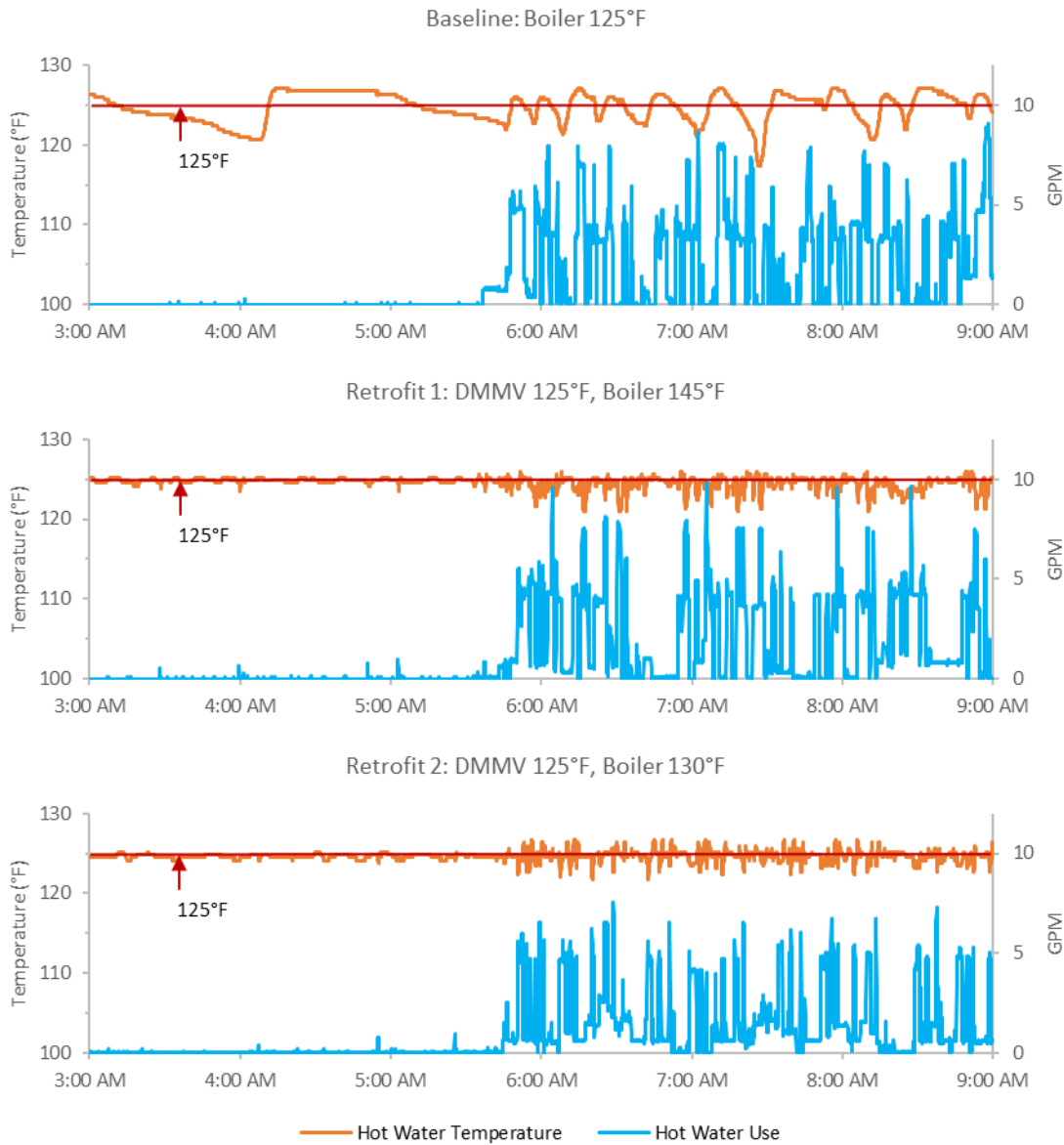
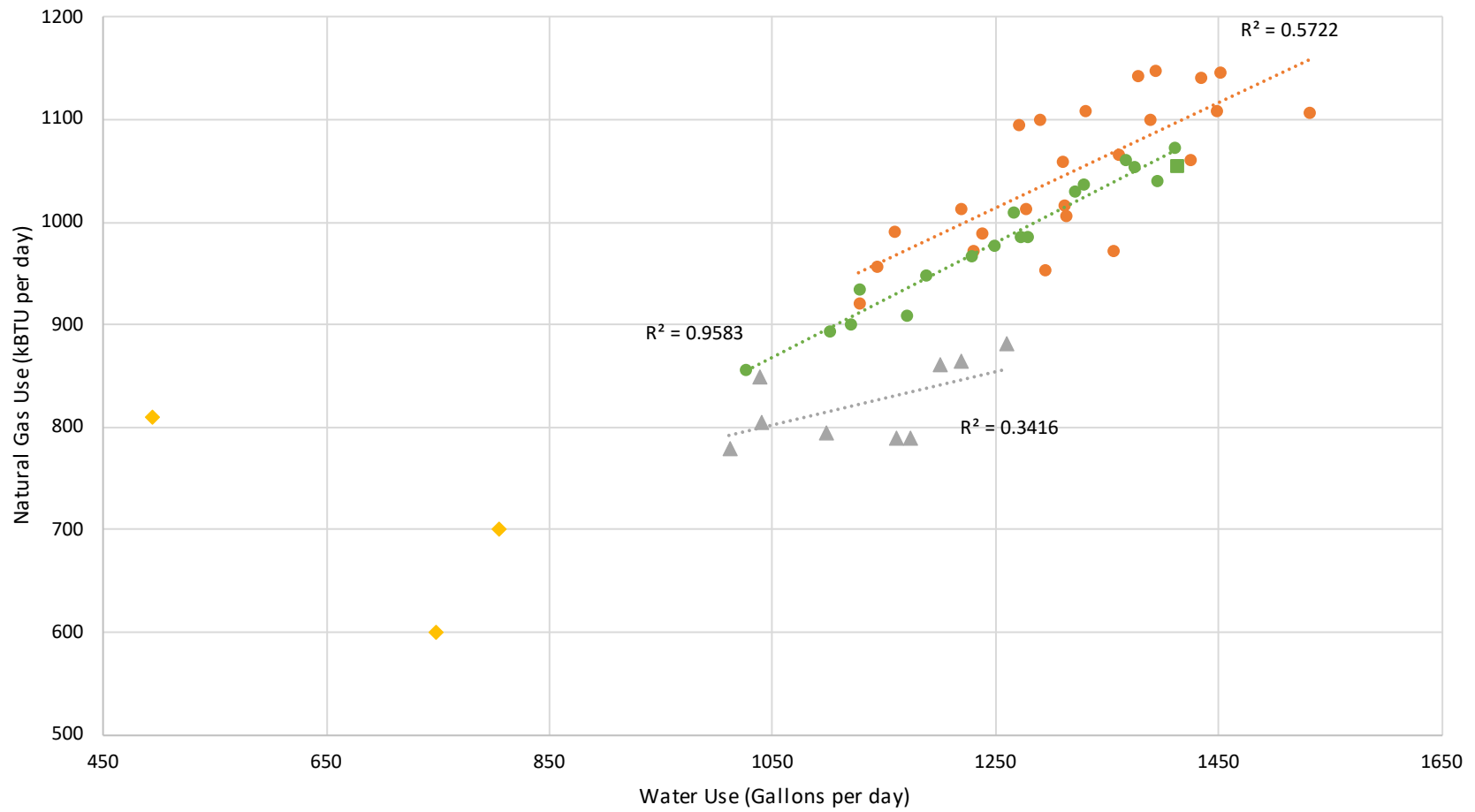

Figure 12: Site 3 Hot Water Delivery Performance

Figure 13 illustrates the daily energy performance of the hot water system over the study period and is provided for additional context when interpreting the results. The figure includes data outliers for a few days with very low flow. These outliers were not used to characterize energy savings because at very low flows a high fraction of the gas use is to maintain the recirculation system temperature rather than to deliver hot water, and the research team found that this negatively impacted the fit of the regression model when the outliers were included. Table 16 summarizes the daily system performance during the monitoring period. The data indicates minor differences in efficiency, run time, and number of cycles.



- ◆ Outliers
- ▲ Retrofit 2: DMMV 125°F Boiler 130°F
- Linear (Retrofit 2: DMMV 125°F Boiler 130°F)
- Baseline: Boiler 125°F
- Linear (Baseline: Boiler 125°F)
- Retrofit 1: DMMV 125°F, Boiler 145°F
- Linear (Retrofit 1: DMMV 125°F, Boiler 145°F)

Figure 13: Site 3 Daily Water Use vs. Natural Gas Use

Table 16: Site 3 Daily System Performance Summary Statistics

Description	Length (Days)	Water Use (gal)	Avg. CWT ³	Avg. HWT ³	Avg. ΔT ³	Natural Gas Use (kBTU)	Delivered Hot Water Energy (kBTU)	Operating Efficiency	Total Heater Run Time (minutes)	Avg. Daily Heating Cycles
Baseline	22	1319	72.3	125.0	52.7	1057	580	54.8%	260	38
Post-retrofit 1 (DMMV 125°F, Heater 145°F)	20	1258	75.8	123.9	48.1	983	504	51.2%	248	37
Post-retrofit 2 (DMMV 125°F, Heater 130°F)	9	1133	77.1	123.9	46.8	833	442	53.0%	216	38

³ Reported average temperatures are arithmetic means of the daily average values

Site 4 (Eye Clinic)

The research team installed the Armstrong DRV-40 DMMV at Site 4 in mid-June 2024. The team began the baseline monitoring June 14 and soon identified that the water meter was reading higher than expected. This was later found to be an additional water using appliance between the water meter and the cold-water inlet to the water heating system which resulted in erroneously high water usage. A qualified contractor was able to make appropriate plumbing changes on July 11 and the baseline monitoring period was restarted. Table 17 lists the key dates for Site 4 and days when system setpoints were changed or equipment commissioned were excluded from the analysis data set. During system monitoring, the research team found that the timer control for the recirc pump was still active even though our plumbing contractor originally believed it was not active. The team also discovered that the site has auto-flushing valves that purge each fixture regularly to decrease water age and reduce the risk of waterborne pathogens. This resulted in much higher than expected flows at night and on the weekends, when the facility is not active.

Table 17: Site 4 Key Dates

Description	Dates (2024)
Baseline monitoring period WH 140°F	7/11 – 7/30
Commission DMMV	7/31-8/8
Post-retrofit monitoring period 1 (DMMV 126°F, WH 140°F)	8/9– 9/3

Table 18 demonstrates the energy savings observed at the site based on regression of the daily average results and corrected for different cold water temperatures. Figure 14 9 shows the hot water delivery performance for the baseline and post-retrofit period and demonstrates that hot water delivery performance during the day is at least equivalent after the DMMV is installed. The results highlight that the manufacturers guidance for the water heater set point is conservative and that for a tank type water heater, the water heater set point can be only 14°F higher than the DMMV (and further reductions may be possible). At night, when the circulator pump is turned off, the hot water temperatures are lower but utility is not reduced since the building is unoccupied at this time.

Table 18: Site 4 Energy Savings Associated with Installing the DMMV

Description	Natural Gas Use (kBtu/day)	Natural Gas Savings (kBtu/day)	Natural Gas Savings (%)
Baseline (water heater 140°F)	173	N/A	N/A
Post-retrofit (DMMV 126°F, Water heater 140°F)	164	8.8	5.1%

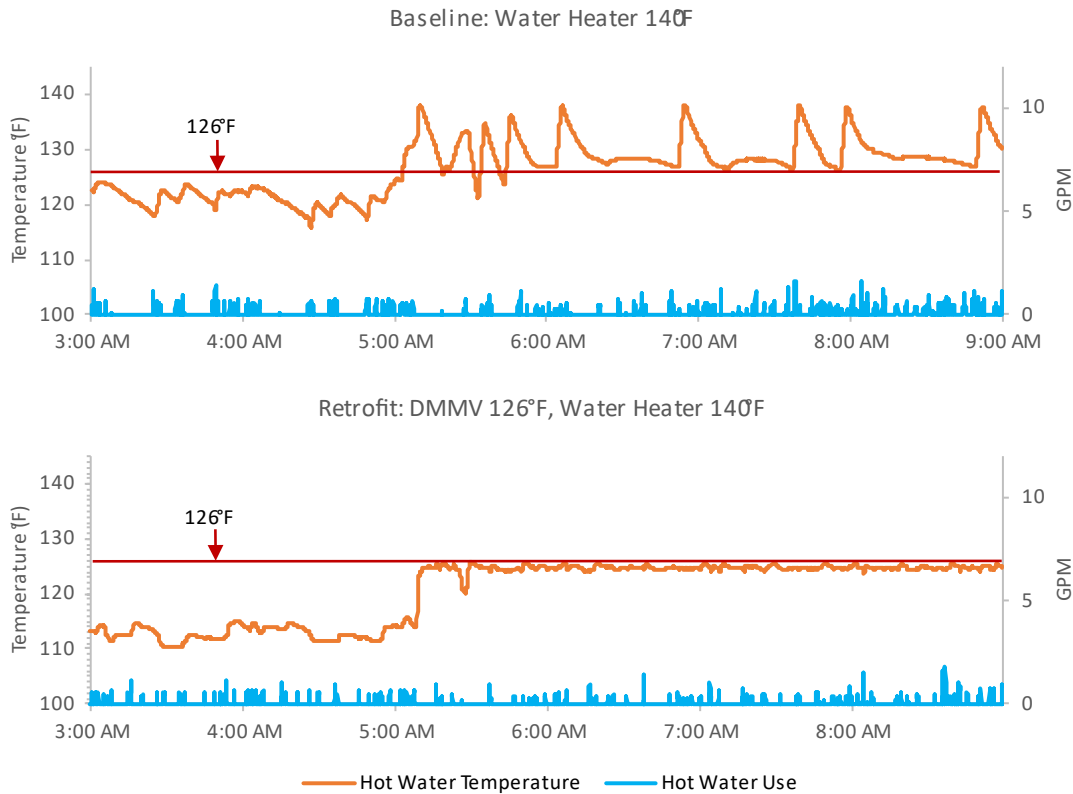

Figure 14: Site 4 DMMV Hot Water Delivery Performance

Figure 15 illustrates the daily energy performance of the hot water system over the study period and is provided for additional context when interpreting the results. Table 19 summarizes the daily system performance during the monitoring period. Both the Figure and the Table highlight the low water use at this site as compared to other sites. Furthermore, the water use is lower in the post-retrofit period while the average cold water temperature is much higher. The research team investigated the cold water temperature measurements

further and determined that mass weighting doesn't work for this site since conduction from the warm recirculation return water to the cold water temperature sensor is significant, the cold water pipe serving the system is oversized at 2" and has excess volume compared to the water use, and water use is low and consists of brief periods of low use, thus the measured pipe temperature is not reflective of the true cold water supply temperature further upstream of the return line. All of these factors mean that the mass weighted cold water temperature is not an effective measure of water entering the system. For this site, the research team used the minimum daily cold water temperature at night when the recirculation system was not operating in place of the mass weighted cold water temperature for the operating efficiency, energy savings and regression analysis. Both values are reported in Table 19.

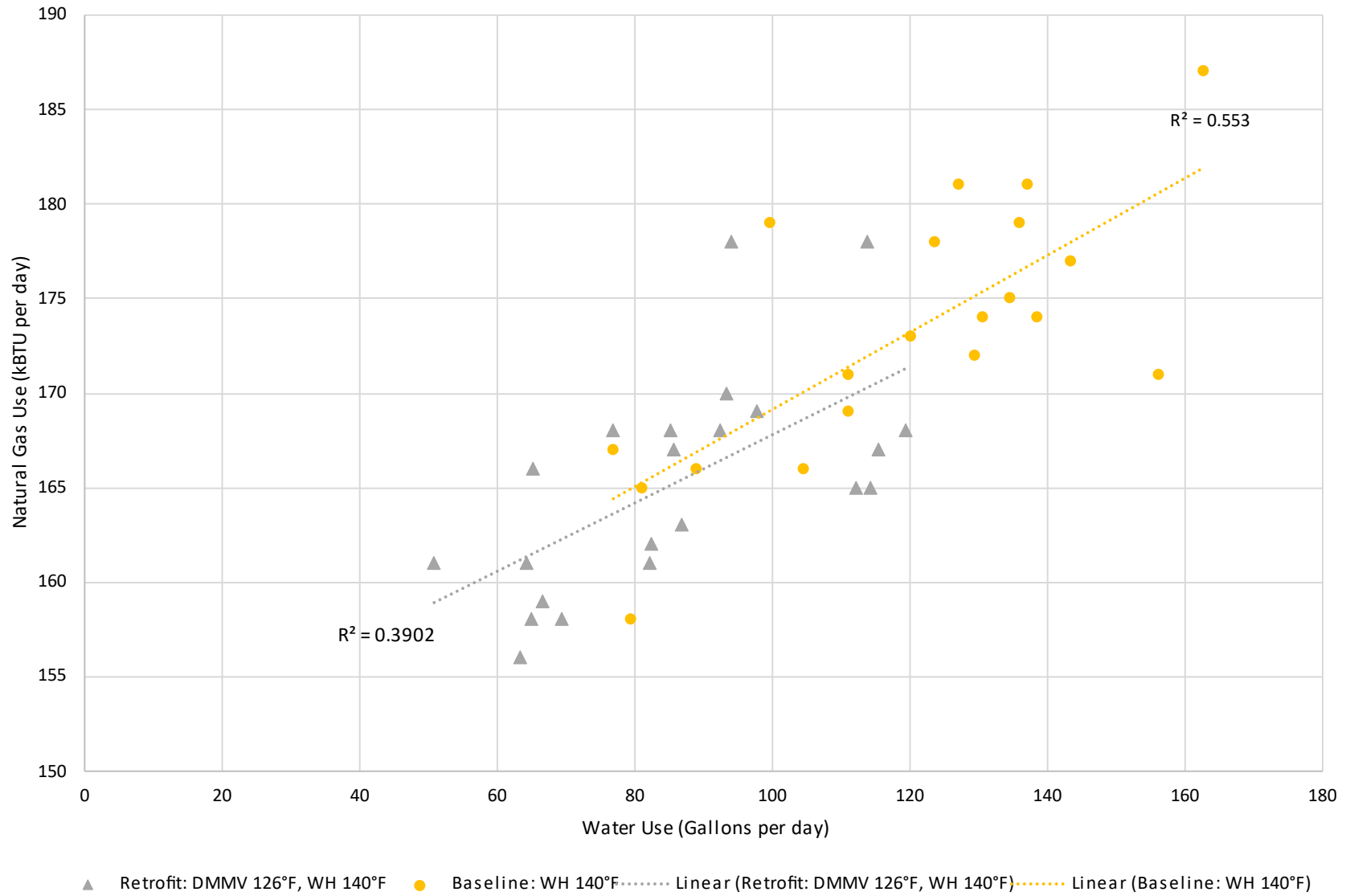

Figure 15: Site 4 Daily Water Use vs. Natural Gas Use

Table 19: Site 4 Daily System Performance Summary Statistics

Description	Length (Days)	Water Use (gal)	Min CWT ⁴	Avg. CWT ⁴	Avg. HWT ⁴	Avg. ΔT ⁴	Natural Gas Use (kBTU)	Delivered Hot Water Energy (kBTU)	Operating Efficiency	Total Heater Run Time (minutes)	Avg. Daily Heating Cycles
Baseline	20	119	81.4	85.3	126.9	45.6	180	45	24.8	71	23
Post-retrofit 1 (DMMV 126°F)	22	86	80.2	91.5	120.3	40.1	172	28	16.4	65	20

The auto-flushing valves were a major source of hot water waste. Roughly 70% of the water was heated, stored, distributed, but did not reach the user of the lavatory sinks, defined as the effective daily water use in Table 20. When the delivered hot water energy to the user is calculated, this value is significantly lower than stated in Table 19. This causes the operating efficiency to drop from 16-25% to an effective operating efficiency of 5-7%

. This centralized DHW system design and operation with minimum daily hot water use around 30 gallons per day produces very low effective operating efficiencies and likely is not the best approach to ensure safe use of tempered water at lavatory sinks.

Table 20: Site 4 Water Waste Adjusted Daily System Performance Summary Statistics

Description	Avg. Daily Water Use (gal)	Weekend Avg. Daily Water Waste (gal)	Effective Daily Water Use (gal)	Delivered Hot Water Energy to User (kBTU)	Effective Efficiency
Baseline	119	86.1	33.4	12.4	6.9%

⁴ Reported average temperatures are arithmetic means of the daily average values

Description	Avg. Daily Water Use (gal)	Weekend Avg. Daily Water Waste (gal)	Effective Daily Water Use (gal)	Delivered Hot Water Energy to User (kBTU)	Effective Efficiency
Post-retrofit 1 (DMMV 126°F)	86	57.8	28.3	9.3	5.4%

Site 5 (51-unit Hotel)

The research team installed the Armstrong DRV-80 DMMV at Site 5 in mid-June 2024 after the owner re-located the new HPWH in an attempt to lower his energy bill. The team performed monitoring at Site 5 from June 13 through August 20. There are three distinct monitoring periods. Table 21 lists key dates associated with Site 5. During the baseline monitoring period the site owner complained to the research team that his bills were too high, and the team advised the owner that the water heater set points were leading to excessive electric resistance activation. The team changed the water heating system setpoints, reducing system energy use by about 40% and began monitoring again during baseline 2, which is the baseline from which DMMV savings are calculated. The analysis excludes days when system settings were changed or equipment commissioned. The post-retrofit analysis period also excludes days where the owner made changes to the site without notifying the research team. The research team corrected the changes and finished monitoring. Throughout the study, the owner was dissatisfied with the energy bills associated with their new HPWH system, and the research team was not able to gather as much data as we intended due to changes made by the owner.

Table 21: Site 5 Key Dates

Description	Dates (2024)
Baseline 1 monitoring period Water Heater 1 140°F, Water Heater 2 120°F	6/13 - 7/1
Baseline 2 monitoring period Water Heaters 1 & 2: 130°F	7/2 - 7/16
Commission DMMV	7/17-7/23
Post-retrofit monitoring period 1 (DMMV 127°F, Water Heaters 1 & 2: 132°F)	7/24 - 7/31, 8/6 - 8/20

Table 22 demonstrates the energy results from adding the master mixing valve. The results show a negative energy savings for the HPWH with equivalent or better delivery performance per Figure 1611, although a couple qualifiers need to be considered. First, the research team raised the set point of the tanks a couple degrees based on our experience with hot water supply temperature excursions at other sites. We intended to reduce the HPWH set point down to 130°F and possibly also reduce the DMMV set point further but were not able to due to challenges at the site and concerns over their laundry process and required end-use hot water temperature. Second, the cold

water temperatures at this site are much higher than expected and the research team suspects crossover is resulting in elevated cold water temperatures in the system. Cold water temperature is higher during the post-retrofit period, and Figure 1813 demonstrates that system efficiency is also reduced during the post-retrofit period. HPWH are more sensitive to entering water temperature than gas systems, and the research team believes that the higher cold water temperature results in a lower efficiency, which our analysis method cannot correct for. The increase in energy use albeit at a higher heater setpoint contradicts prior lab research, and future work should continue to understand the savings potential for HPWH.

Table 22: Site 5 Normalized Energy Savings Associated with Installing the DMMV

Description	Energy Use (kBTU/day)	Energy Savings (kBTU/day)	Energy Savings (%)
Baseline 1 Water Heater 1 140°F, Water Heater 2 120°F	709	N/A	N/A
Baseline 2 Water Heaters 1 & 2: 130°F	363	N/A	N/A
Post-Retrofit (DMMV 127°F, Water Heater 132°F)	384	-18	-4.9%

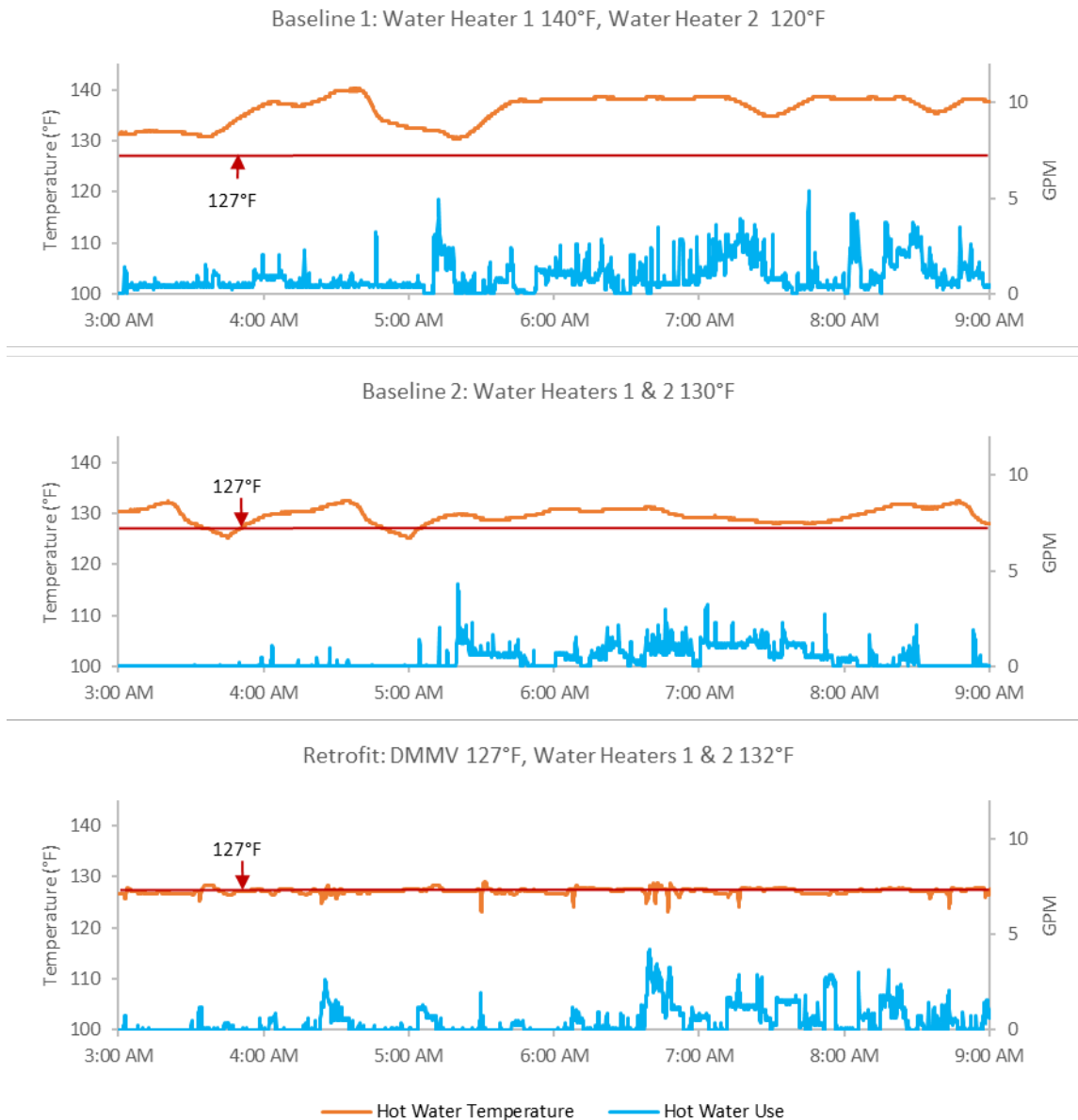

Figure 16: Site 5 Hot water delivery performance

Figure 17 illustrates the daily energy performance of the hot water system over the study period and is provided for additional context when interpreting the results. Table 23 summarizes the daily system performance during the study period, and in particular demonstrates the poor system efficiency of the integrated HPWH observed at this site with hot water recirculation.

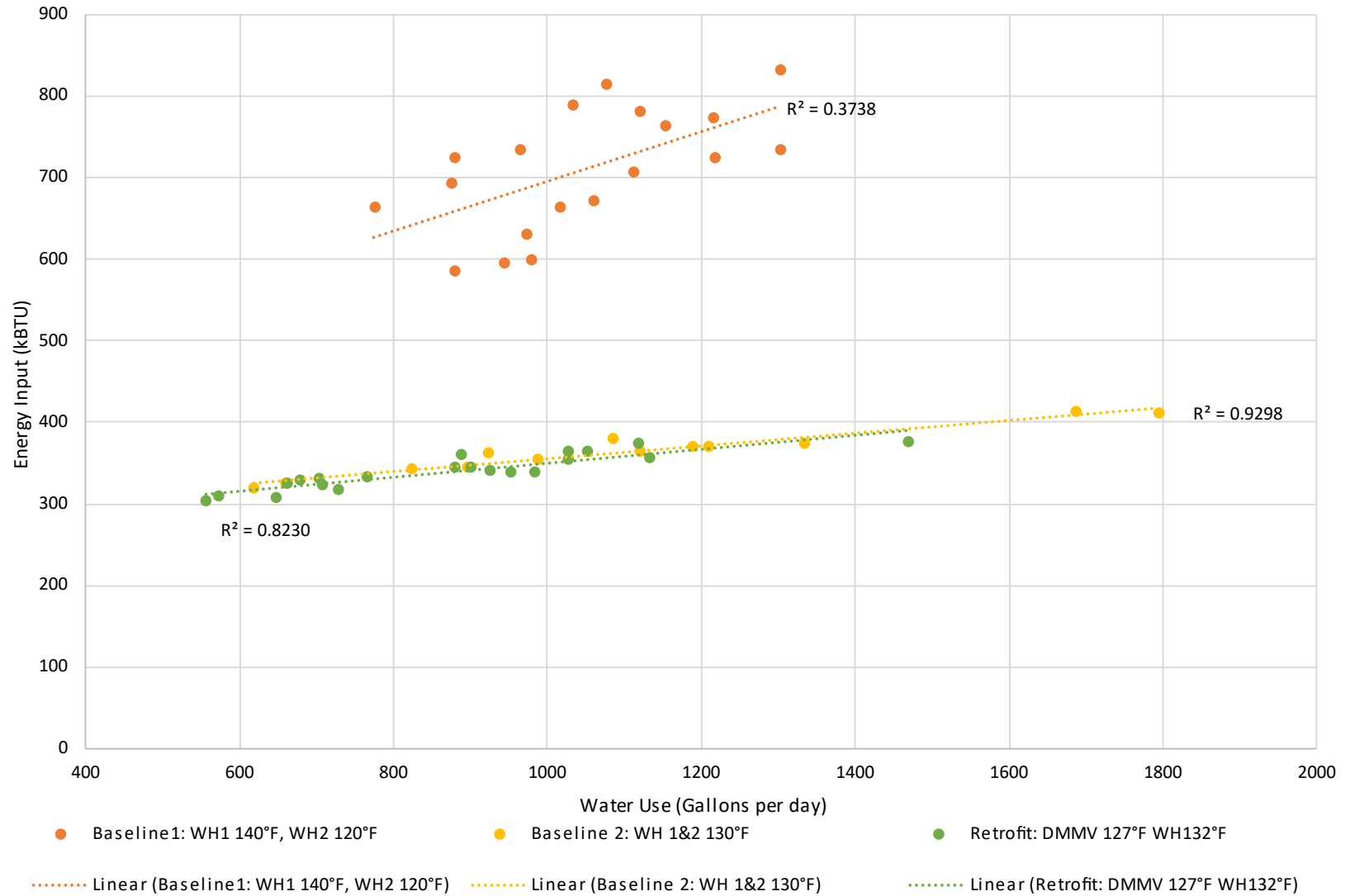

Figure 17: Site 5 Daily Water Use vs. Energy Input

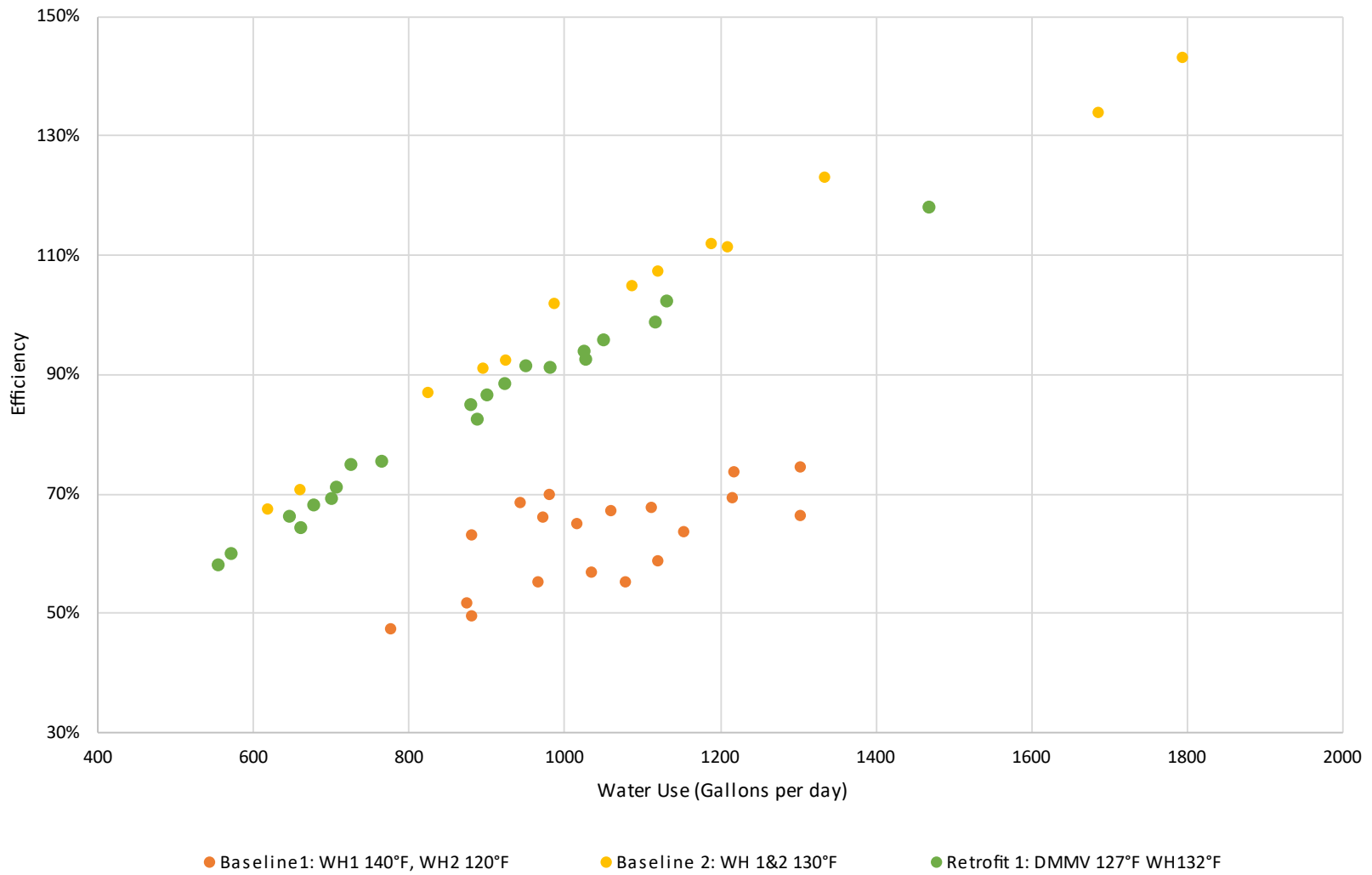

Figure 18: Site 5 Water Use vs. System Efficiency

Table 23: Site 5 Daily System Performance Summary Statistics

Description	Lenth (Days)	Water Use (Gal)	Avg. CWT ⁵	Avg. HWT ⁵	Avg. ΔT ⁵	Energy Use (kBTU)	Delivered Hot Water Energy (kBTU)	Operating Efficiency	Total Heater Run Time (minutes)	Avg. Daily Heating Cycles
Baseline 1	19	1045	82.3	133.1	50.8	709	444	62.7%	1413	8
Baseline 2	14	1092	85.0	127.1	42.1	364	380	103.2%	1336	8
Post-retrofit (DMMV 127°F)	26	908	87.2	126.1	39.4	338	338	86.0%	1394	12

⁵ Reported average temperatures are arithmetic means of the daily average values

Key Findings

This field study is the first field study to evaluate the energy savings of DMMV installed in real domestic hot water systems in commercial and multifamily buildings. The evolution of the project included continuous improvement by the research team based on learning and observations at past sites. As such, the research team updated certain components of our approach as we learned more about the behavior of the DMMV.

At Site 1, the research team observed excursions in the hot water supply temperature that we deemed acceptable, based in part on feedback from the site owner and his staff which indicated that hot water delivery performance was not compromised. The observed temperature excursions are in-line with experience the research team has from lab testing of DMMV and shows that the valve takes time to reduce the mixed ratio of cold/recirculated water vs. hot water when a hot water draw is initiated. The research team also observed crossover at Site 1 which indicates that the site may be accustomed to reduced hot water delivery performance. While there are significant hot water supply temperature excursions that reduce the overall average hot water temperature, they are short lived and probably have only a minor effect on savings. The circulator pump timer also reduces the site savings as compared to a site with continuous recirculation, and the research team concludes that the reported savings is reasonably correct. Finally, the data at Site 1 shows that installation of the DMMV has a more significant impact on savings than subsequent minor modifications of the DMMV set point.

At Site 2, the research team observed that the baseline water heater had a larger deadband than the water heater at Site 1. When the research team commissioned the DMMV with an appropriate set point, the data showed that the DMMV was not able to operate correctly and there were extended periods with reduced hot water delivery performance which is attributed to periods when the tank temperature was lower than the DMMV set point. The research team consulted with the manufacturer who referred us to standard guidance that the water heater set point should be 20 °F higher than the DMMV set point. The research team tested the strategy and was able to achieve improved hot water delivery performance and save energy as opposed to baseline, however the energy savings were marginal at 1.0%. Based on testing at subsequent sites, the research team believes that energy savings could be improved further without impacting hot water delivery performance if the water heater were set to 140 °F and believes that manufacturer guidance for water heater set point can be reduced to improve savings.

The system type at Site 3 was originally a low priority target for the research team since split gas water heaters with recirculation spend more time de-stratified and therefore were thought to have less savings potential than integrated gas water heaters. The first post-retrofit configuration showed that when the water heater is set to 20 °F above an appropriate DMMV set point, energy use goes up. This result is in contrast with the results at Site 2 where the same configuration resulted in low savings and illustrates that split gas water heating systems do in fact behave differently than integrated gas water heaters. Next, the research team reduced the Site 3 water heater set point to 130 °F and kept the DMMV set point at 125 °F for a 5 °F set point difference. The results show significantly more energy savings in this configuration with acceptable hot water delivery

performance and the result shows that split gas water heating systems should also be considered for future DMMV programs.

Site 4 was an atypical site with automatically flushing valves and a requirement for 140 °F tank set point regardless of DMMV set point. The automatically flushing valves run 24/7 and result in water use when the building is unoccupied. Selection of the DMMV set points was more challenging for this site due to the circulator pump being off at night while there are still significant fixture draws. The research team selected the DMMV set point to match the average hot water supply temperature, consistent with how we selected the DMMV set point for other sites. This method resulted in significantly reduced hot water delivery temperatures at night, however since there is no specific temperature requirement for the nighttime use, which is attributed to automatic flushing, the research team found the change acceptable. During operating hours, if the initial warmup period associated with the circulator pump turning on is included, the DMMV set point meets the criteria for equivalent performance. If the same warmup period is excluded however, the DMMV set point appears to be optimized by a couple degrees. The research team made the decision to maintain the DMMV set point as is based in part on the results at Site 1 which show that the savings results are not very sensitive to minor changes in DMMV set point of a couple degrees.

Site 5 is a HPWH site and is the only site that showed increased energy use with the DMMV. The research team came up with theories that could explain the lack of energy savings and had planned an additional test to try to achieve savings. Unfortunately, the research team and the site ran into challenges after the site had a routine service of the HPWH and the final test was not conducted. Although it's possible that there is not much savings potential at the site with a DMMV, the research team believes it's unlikely that the DMMV caused higher energy use. Instead, the team attributes the higher energy use to a slightly increased tank set point of 132 °F (as opposed to 130 °F in the baseline period), and slightly higher average cold water inlet temperature. In general, the results show that increased tank set point reduces savings, however the set point change was marginal which could mean that HPWH are more sensitive to small changes in tank set point. The result shows that set point selection is a critical component of DMMV installation. Future work should investigate the implications of this result for load flexibility which is currently thought to be a benefit of DMMV installation.

The energy savings findings for five sites are summarized by site and configuration in Table 24. The baseline system key set points are shown first in the table, followed by each post-retrofit period and associated savings. The findings show that savings can be achieved with DMMV, however savings are sensitive to how the DMMV and the heating system are configured.

Table 24: Site System Types and DMMV Energy Savings

Site	System Type	Baseline Tank Set Point	Test A: Retrofit Set Points	Energy Savings	Test B: Retrofit Set Points	Energy Savings
Site 1	Condensing gas fired, Integrated tank	140 °F	Tank: 140 °F DMMV: 137 °F	11.4%	Tank: 140 °F DMMV: 135 °F	10.0%
Site 2	Atmospheric gas fired, Integrated tank	130 °F	Tank: 153 °F DMMV: 133 °F	1.0%	Tank: 130 °F DMMV: 133 °F	6.8%
Site 3	Atmospheric gas fired, Split system	125 °F	Tank: 130 °F DMMV: 125 °F	7.3%	Tank: 140 °F DMMV: 125 °F	-4.4%
Site 4	Condensing gas fired, Integrated tank	140 °F	Tank: 140 °F DMMV: 126 °F	5.1%	-	-
Site 5	HPWH, Integrated tank	130 °F	Tank: 132 °F DMMV: 127 °F	-4.9%	-	-

Table 25 summarizes the best estimates of energy savings for each site as well as the overall average energy savings results associated with installing DMMV based on all five sites, which is 4.5%.

Table 25: Best Estimates of Energy Savings

Site	System Type	Baseline Tank Set Point	Best Estimate of Savings	Notes
Site 1	Condensing gas fired, Integrated tank	140 °F	10.7%	Savings estimate is based on average of post-retrofit Test A and Test B.
Site 2	Atmospheric gas fired, Integrated tank	130 °F	4.3%	Savings estimate is interpolated from Test A and Test B savings assuming a 140 °F water heater set point and a 133 °F DMMV set point. Observations at other sites indicate a 140 °F water heater set point would provide sufficient hot water delivery performance.
Site 3	Atmospheric gas fired, Split system	125 °F	7.3%	Test A is a representative savings estimate and saves energy while maintaining hot water delivery performance.
Site 4	Condensing gas fired, Integrated tank	140 °F	5.1%	Test A is the only result. Test A is a representative savings estimate and saves energy while maintaining hot water delivery performance.
Site 5	HPWH, Integrated tank	130 °F	-4.9%	Test A is the only result.
Average of all sites	N/A	N/A	4.5%	Average savings from five sites.

Results and Recommendations

The results demonstrate that DMMV can result in savings of up to 11.4%, but that there is variability in the savings depending on the hot water system type. On average, a savings of 4.5% were achieved without sacrificing hot water delivery performance, and in some cases the DMMV saved energy and improved hot water delivery performance. The results show agreement with the gas savings estimates of 3% to 10% estimated in prior research, but the integrated HPWH didn't show agreement with laboratory research that show savings for a variety of split heat pump configurations ranging from 6.5% to 18.0%, however the research team concludes that more work needs to be done and that challenges with the HPWH site we demonstrated at kept us from realizing the full savings potential of the DMMV. In particular, future work should look at reducing how much higher the water heater set point is than the DMMV set point. Additionally, we plan to make recommendations to the DMMV manufacturer we worked with to reduce hot water supply temperature excursions without having to increase tank set point, and future work should also determine if other DMMV manufacturers have controls that already achieve this result. Future work should investigate if valve sizing and proper sizing impacts valve response time, and if proper sizing can allow for lower DMMV set points.

Optimization of the DMMV set point has an effect on energy savings, although the savings from optimizing the DMMV set point is lower than the savings of installing DMMV in the first place. At site 2, the research team also observed that the set point of the water heater can be increased dramatically after installing the DMMV while maintaining savings of 1.0%, showing that sites can benefit from non-energy benefits such as enhanced legionella kill while also maintaining the energy benefits associated with the DMMV.

While the field study shows significant potential for DMMV to save energy in light commercial and multifamily applications, the team observed market challenges that need to be considered as part of any future program design. During site selection the team observed deficient installation and operation of hot water systems such as lack of existing check valves at domestic cold-water inlet to the water heating system and the set points that are too low for safe operation of the application. The lack of check valves is so prevalent that we had no choice but to install the DMMV at sites without check valves. One contractor told us that he almost never observes check valves serving existing water systems in the target segment. The research team also observed significant evidence of crossover at some of the sites, although this was not the focus of the study. Prior work estimates that crossover is highly prevalent in multifamily and commercial systems and can account for 1/3 of all hot water system energy use, further highlighting the need to correct crossover in existing systems (Ayala and Zobrist 2016). The eye clinic and the senior care facility stand out as exceptions to our general observations and had generally well performing hot water systems without noted deficiencies which is likely due to the sensitivity of those applications to scalding and waterborne pathogens.

Despite the poor operations of existing systems in the market segments this study targeted, the results show that DMMV can achieve savings while also enabling owners to improve their operations. The key challenge for future DMMV programs will be the need for quality control and training as part of the program implementation, and contractors serving the target market segment are not likely to have the skills required to install DMMV without training and oversight. An example of a successful

program implementation would be to deploy DMMV in existing light commercial buildings as part of a retro-commissioning program where other system deficiencies such as crossover, improper set points, and lack of check valves can be addressed. Additional considerations that this study does not address but is important is to ensure right sizing the DMMV for best performance. Such a program could market the non-energy benefits the research team observed, such as increased hot water capacity while reducing energy use. Future research should investigate the savings potential and non-energy benefits associated with such a retro-commissioning program (for instance, what are the savings associated with reducing plumbing crossover).

Other program opportunities include advancing the use of DMMV in new installations, especially in commercial segments where the scope of the project is likely to require a contractor that has sufficient knowledge to correctly install the DMMV such as large commercial end uses that are more educated on the risks associated with poorly functioning hot water systems such as clinics, senior care facilities, and other similar end uses. The codes and standards enhancement program is an example of a program that could be suited to address new facilities that meet these characteristics through code language additions and additional installation, commissioning and verification requirements in the reference appendices.

References

- California Energy Codes & Standards. 2023. Prepared by Jingjuan “Dove” Feng, Amin Delagah, Jose Garcia (TRC), and James Haile (Frontier Energy). *Multifamily Domestic Hot Water - Final CASE Report*.
https://title24stakeholders.com/wp-content/uploads/2023/08/2025_T24_CASE-Report-MF-DHW-Final-1.pdf
- ASHRAE Guideline 12. 2017. *Managing the Risk of Legionellosis Associated with Building Water Systems*. Prepared by ASHRAE (American Society of Heating, Refrigerating, and Air-Conditioning Engineers, Inc.).
- ASHRAE Guideline 188. 2018. *Legionellosis: Risk Management for Building Water Systems*. Prepared by ASHRAE (American Society of Heating, Refrigerating, and Air-Conditioning Engineers, Inc.).
- Ayala, Gabriel and Derek Zobrist. 2016. “Testing for and Determining the Prevalence of Crossover in a Multifamily Central Domestic Hot Water Distribution System.” Presented at the ACEEE Summer Study on Energy Efficiency Buildings.
https://www.aceee.org/files/proceedings/2016/data/papers/1_59.pdf